

Industrial Products Catalog

High Pressure Valves

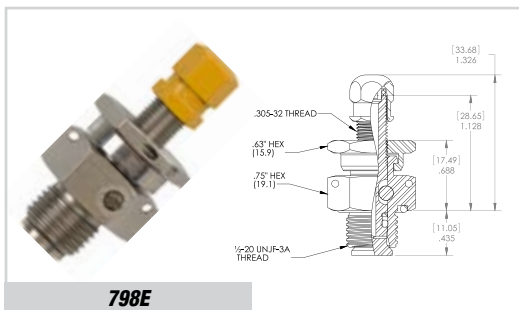

High Pressure Valves

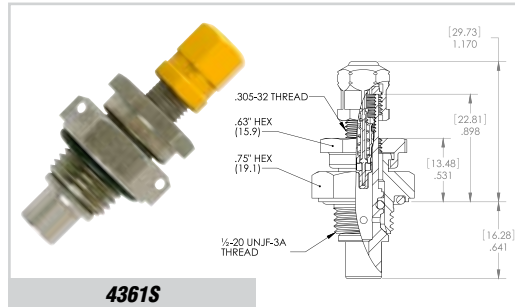
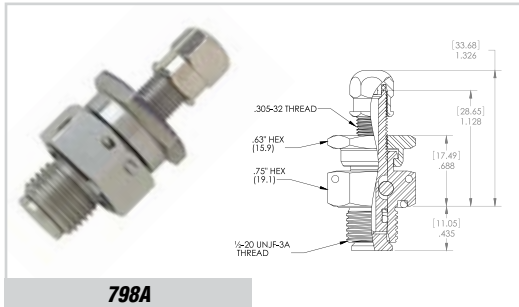
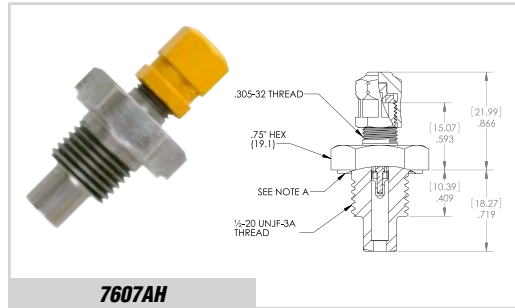
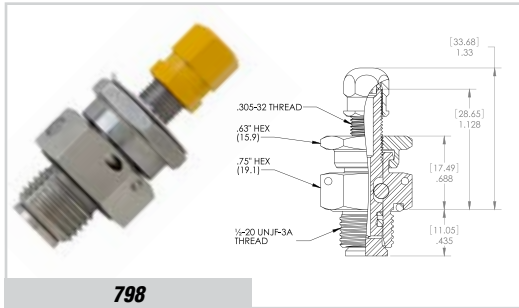

Schrader High Pressure Valves are constructed of stainless steel bodies and are intended for use in high-pressure air-charged units such as shock absorber struts, hydraulic pressure accumulators, surge cylinders, and pneumatic systems. These valves have a special feature, which warns of unreleased air pressure when the valve is being separated from the outlet. Contact Schrader for further information on military and commercial adaptations. Valves have 1/2"-20 U.N.F.-3A threads for connection to container.

High Pressure Valves

Part Number	Generic Number	AN/MS Number	Cap	Core	Working Pressure (PSIG)	Remarks
007987105	798	M-6164-2	2525	-	5,000	
007987109	798A	M-6164-5	7612	-	5,000	Meets Boeing spec. BAC-V10T, Nickel plated cap
007987311	798E	M-6164-2	2525	-	5,000	Lockwire holes in swivel nut
043617010	4361S	AN-6287	2525	2300	3,000	
076070949	7607AH	AN-812-1	2525	9914	4,000	

High Pressure Inflating Connectors



These high pressure inflating connections attach securely by hand or wrench to the valve cap threads of high pressure valves. They can be fitted to gauging and inflating devices by a variety of methods. Various angles permit easy attachment to hard-to-reach valves.

High Pressure Inflating Connectors

Part Number	Generic Number	Thread Size	Air Line Connection	Max. Pressure (PSIG)	Configuration	Recommended Max. Torque to Valve Mouth*	Remarks
005560099	556	.305"-32	1/8" NPT Male	3,000	Air line connection 90 to axis of valve	50 in.-lb.	Has core depressor pin, copper sealing washer 02550080
027550169	2755	.305"-32	3/8"-24 thread for 3/16" flare tube fitting, meets MS 33656E3	3,000	Air line connection 90 to axis of valve	50 in.-lb.	Has core depressor pin, copper sealing washer 027550080
027550008	2755 Large Bore	.485"-26	3/8"-24 thread for 3/16" flare tube fitting	3,000	Air line connection 90 to axis of valve	50 in.-lb.	Has core depressor pin, copper sealing washer 027550080
050070099	5007	.305"-32	7/16"-20 thread for 1/4" flare tube fitting, meets MS 33656E4	15,000	Straight	75 in.-lb. for steel valves	Copper sealing washer 027550080
061160001	6116	.305"-32	1/8" NPT Female	3,000	Air line connection 70 to axis of valve	30 in.-lb.	Hard fiber sealing washer 5/32" ID x 3/8" OD x 1/16" Thick
057840099	5784	.305"-32	7/16"-20 thread for 1/4" flare tube fitting, meets MS 33656E4	5,000	Air line connection 70 to axis of valve	30 in.-lb.	Hard fiber sealing washer 5/32" ID x 3/8" OD x 1/16" Thick

* It may be necessary to replace the sealing washers after a number of uses to insure sealing on valve mouth





*205 Frazier Road
Altavista, VA 24517*

Tel: +1 434-369-4741

schrader-bridgeport.com

HPVALVES-0411